

# Amateur Radio Astronomy

2nd edition

John Fielding, ZS5JF



Radio Society of Great Britain

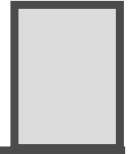

---

# Contents

● Foreword .....	1
1 A Brief History of Radio Astronomy .....	5
2 Radar Astronomy .....	39
3 Receiver Parameters .....	77
4 Antenna Parameters .....	117
5 Early Low Noise Amplifiers .....	179
6 Assembling a Station .....	187
7 50MHz Meteor Radar System .....	209
8 Practical Low Noise Amplifiers .....	235
9 Assessing Receiver Noise Performance .....	257
10 Station Accessories .....	267
11 Low Frequency Radio Astronomy .....	273
12 The Science of Meteor Scatter .....	279
13 A Hydrogen Line Receiving System .....	303
14 Mechanical System Considerations .....	343
● Appendix 1: Hart RAO KAT Demonstrator Antenna .....	367
● Appendix 2: Further Information .....	373
● Index	

# A Brief History of Radio Astronomy

## *In this chapter:*

- Pioneers
- The war years
- German wartime radar
- The birth of the big telescope
- Lunar radar - moonbounce or EME
- Parkes radio telescope

**T**his is a fascinating period in the development of the science and, as will be seen, although some of the results confirmed earlier optical observations, many experiments gave conflicting answers and, in many cases, opened up further areas of investigation, some of which are still on-going. Many amateur radio operators figured in the early period and with their aptitude for problem-solving and constructing complex equipment, the science advanced rapidly.

## PIONEERS

### Sir Oliver Lodge

Sir Oliver Joseph Lodge was one of the great pioneers in radio communication history, but very few people today have even heard of him. Lodge's discoveries in radio and electricity were revolutionary. They turned what was inconceivable in Victorian times into part of everyday life. His ideas have since been incorporated into millions of pieces of equipment working all over the world. Yet Lodge was more than a brilliant scientist. He was a professor of physics at 30, at the time an unheard of achievement in Britain, and later the first principal of Birmingham University College, an author of many books, a lecturer who attracted huge audiences, and a much-appreciated broadcaster.

In 1877 he was awarded the Doctor of Science degree (D Sc now called Ph D) and employed as a lecturer for several years. Lodge became assistant professor of applied mathematics at University College, London in 1879 and was appointed to the chair of physics. In 1881 he was appointed Professor of Physics at the newly formed Liverpool University College, setting a precedent, as he was just

*Note: Several of the dimensions quoted in this book are in imperial measurements, as originally presented in the various publications*

30 years old. He wrote his first book, *Elementary Mechanics*, at 26. Many years later, Lodge wrote in his autobiography: "At an early age I decided that my main business was with the imponderables, the things that work secretly and have to be apprehended mentally." He spent 19 years as professor of experimental physics at the new Liverpool University College before his academic career reached its peak in 1900 when he was appointed the first principal of Birmingham University College.

Whilst at Liverpool, apart from his academic duties, he was busy experimenting with the transmission of radio waves along wire conductors. This was demonstrated in 1888. His great friend and scientific rival Heindrich Hertz in Germany worked on the transmission of radio waves through the ether. Lodge developed a new detector for radio waves, which he called a 'coherer'. This was based on the earlier experiments made by Edôard Branley in France. Lodge's version improved the detector, which consisted of finely ground metallic particles in a glass tube with electrodes, by the addition of a mechanical trembler that shook the particles after each reception of radio waves to stop them from sticking together (cohering). The new coherer exhibited a varying resistance when acted on by radio waves. This detector when used with a voltaic cell and a mirror galvanometer caused a spot of light to be moved on a projection screen. Lodge took out a world wide patent for his version of the coherer.

In 1894 at a meeting of the British Association for the Advancement of Science in Oxford, Lodge demonstrated in front of a packed lecture room the reception of Hertzian waves. This used the new coherer connected to an inker (as used for Morse telegraphy using wires) that produced marks on a piece of paper. This was the first recorded reception of wireless telegraphy anywhere in the world. This was almost exactly one year before Marconi performed the same demonstration in Italy. As well as the coherer, Lodge obtained patents in 1897 for the use of inductors and capacitors to adjust the frequency of wireless transmitters and receivers.

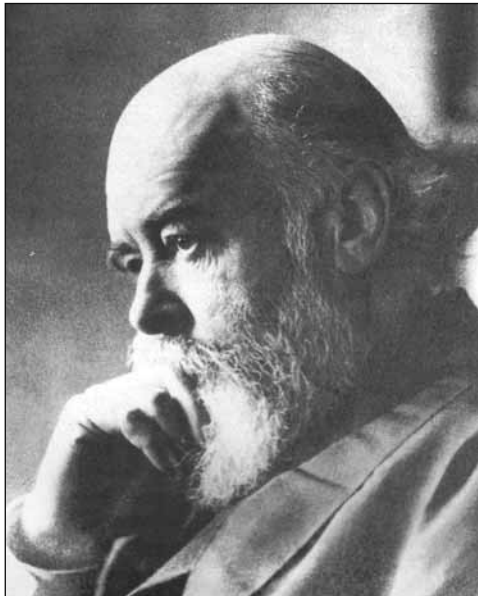

**Fig 1.1: Renowned physicist and RSGB Past President, Sir Oliver Lodge**

When Marconi arrived in England in February 1896 and demonstrated his wireless apparatus, Lodge saw that it infringed on his patents and he sued Marconi. The result of this protracted legal battle was that Lodge eventually won the patent case and Marconi was liable for large damage payments. In order to appease Lodge the young Italian appointed Lodge as the official scientific advisor to the now prosperous Marconi Company. Marconi applied for and was granted a patent for wireless telegraphy on 2 June 1896 not being aware of Lodge's prior application for this new mode of communication.

It was to take until 1942 for Marconi's patent to be declared null and void by a court in the USA, after both he and Lodge were dead.

Lodge also experimented with what today we know as radio astronomy, although the science was only recognised later. In Liverpool he set up an experiment to receive signals from the Sun. His contemporaries believed he was quite mad to consider such a possibility. He devised an ingenious method where his coherer was mounted behind a blackboard to exclude the light rays but allowing the longer radio waves to pass through. (Lodge had noted that the coherer was susceptible to strong sunlight falling on it and this predates the invention of photo-electric cells by almost 50 years. Lodge did not pursue this line of research and others some time later discovered the same effect). Lodge was later to write of his experiment:

"I did not succeed in this, for a sensitive coherer in an outside shed unprotected by the thick walls of a substantial building cannot be quiet for long. I found the spot of light liable to frequent weak and occasionally violent excursions, and I could not trace any of these to the influence of the Sun. There were evidently too many terrestrial sources of disturbance in a city like Liverpool to make the experiment feasible" (The spot of light refers to Lodge's mirror galvanometer).

He was only proven to be correct in 1942. Lodge had correctly calculated from Maxwell's equations that the Sun must be a strong source of electromagnetic radiation. Unfortunately his coherer and mirror galvanometer were not sensitive enough to detect the radio waves from the Sun and Liverpool city centre was a very noisy electrical environment, causing erratic measurements, so his experiment was deemed to be a failure.

One of the early beliefs amongst scientists working on Hertzian waves was the mysterious 'ether' that was assumed to be responsible for the transmissions. Lodge although at the time a believer in this unseen matter devised an experiment to prove its existence. His experiment however proved it was a figment of the imagination, and led to the dropping of this concept. Hertz in Germany later confirmed Lodge's findings about the ether.

Lodge also studied the electromagnetic waves caused by lightning discharges and how the waves propagate over long distances. He postulated that there was some invisible layer high above the Earth that allowed these "crashes" to be reflected and heard over a wide area. This was proven several years later by others and given the name 'ionosphere' by Robert (Watson) Watt. It is largely due to Lodge's research that Marconi had the idea that radio waves could travel across large distances, culminating in his transatlantic radio experiments.

Note: Prior to February 1942 when the knighthood was bestowed on him, Watson-Watt was named Robert Alexander Watt. Upon becoming Sir Robert he added the hyphenated Watson-Watt.

### **Guglielmo Marconi**

Although Marconi is not considered by many people to have made any significant input to astronomical science, this is not so. Due to his pioneering work in demonstrating that trans-Atlantic radio communications was possible, the scientific world at the time then had to explain how it was possible.

Up until 1901, when Marconi and his colleagues succeeded in sending radio signals across the Atlantic from Poldhu in Cornwall to Newfoundland, the belief was that radio waves, like light waves, only travelled in straight lines. After his

**Fig 1.2: Guglielmo Marconi**



success, the scientific world was left with the problem of how this had occurred, and fairly soon it became apparent that the radio waves were being bent or refracted by the upper atmosphere. This refraction was deduced to be due to the effect of the Sun's ultra-violet radiation releasing free electrons in the rarefied upper atmosphere, the ionosphere, to behave like a radio 'mirror', allowing radio waves to be returned to earth at great distances from the source.

From the 1920s to the present day, the science of the refracting mechanism in the ionosphere has been studied using ionospheric sounding apparatus, both from the surface of the earth and from sounding balloons and rockets. The early result from these studies was that radio waves were unable to penetrate the ionosphere and hence were prevented from passing into space. This theory was turned on its head a few years later!

Marconi developed a practical microwave link to join the Italian telephone network to the summer residence of the Pope and, in 1922, proposed the use of radio waves to detect objects, many believe this to be the first attempt at radar. Although Marconi did not find much favour for his idea, this was taken up by others and pursued to its conclusion. In an address to the American Institute of Radio Engineers (IRE) in 1922 Marconi stated:

"As was first shown by Hertz, electric waves can be completely reflected by conducting bodies. In some of my tests, I have noticed the effects of reflection and detection of these waves by metallic objects miles away.

"It seems to me that it should be possible to design apparatus by means of which a ship could radiate or project a divergent beam of these rays in any desired direction; which rays, if coming across a metallic object, such as another steamer or ship, would be reflected back to a receiver screened from the local transmitter on the sending ship, and thereby, immediately reveal the presence and bearing of the other ship in fog or thick weather."

Marconi had obviously not heard of Christian Hulsmeyer or his patent of 1903 where he not only proposed the idea but also built a working system and demonstrated it.

In the light of Marconi's address, two scientists at the American Naval Research Laboratory (NRL) determined that Marconi's concept was possible and, later that same year (1922), detected a wooden ship at a range of five miles using a wavelength of 5m using a separate transmitter and receiver with a CW wave. In 1925, the first use of pulsed radio waves was used to measure the height of the ionospheric layers, radar had been born. (RADAR is the acronym for Radio Detection and Ranging.)

### **Karl G Jansky - USA**

Between 1930 and 1932, Karl Jansky, an engineer working for the Bell Telephone Corporation Laboratory, (BTL) in Belmar, New Jersey was investigating the problem of interference to long-distance HF ship-to-shore radio links. This took the form of bursts of noise or a hissing sound and was seemingly of a random nature.

In order to study this interference, Jansky constructed a large multi-loop Bruce antenna array supported on a framework of wood and mounted this on old Ford Model T wheels to allow it to be rotated and pointed in various directions. This became known as Jansky's 'merry-go-round'. It was set up in a potato field in New Jersey. The antenna and receiver worked on a frequency of 20.5MHz (14.6m).

Jansky discovered that the noise emanated from two different sources, lightning-induced noise (at any one time there are an estimated 1,800 different lightning storms in existence), and also a noise that appeared when the antenna was pointed in a particular direction at the same time every day, but Jansky could not immediately correlate this to any known source. Further careful observations showed the rather startling fact that the time between successive peaks was not 24 hours but was 23 hours and 57 minutes, which is the time taken for the earth to complete one revolution, the sidereal day. (In actual fact, a sidereal day is 23hr 56m 4s).

Jansky correctly deduced in 1932 that the source must be extra-terrestrial and suggested a source in the Milky Way, Sagittarius, which meant that the source was about 25,000 light years distant. In view of the impossibility of curing the interference, Jansky was removed from the project; the one credit to him was

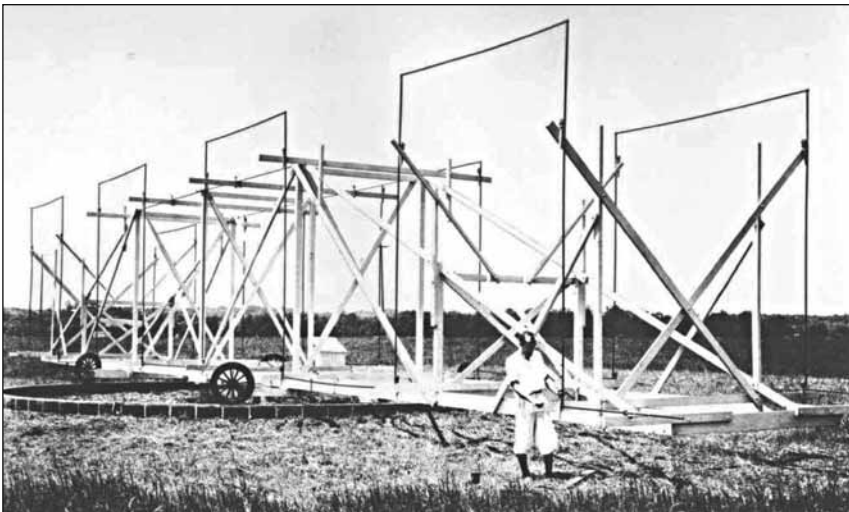

**Fig 1.3: Karl Jansky and his 'Merry-Go-Round' antenna**

the naming of the radio flux unit, the jansky (Jy). His paper was published in 1933 [1]. Jansky's work brought to the attention of scientists that a 'radio-window' existed in the earth's ionosphere, similar to the window through which light from distant stars was also able to reach the earth's surface. This was an extremely important discovery, and from this the science of radio astronomy advanced rapidly in later years.

Karl Jansky was the son of a brilliant scientist and he, in turn, became like his father. After his work on the ionospheric disturbances was concluded, Jansky was retained by Bell Telephone Laboratories (BTL) as an expert on interference matters and provided valuable assistance during the war years to the American Armed forces, receiving an Army-Navy citation for his work in direction finding to detect enemy transmitters. Jansky tried to persuade BTL to build a 100ft radio telescope to study the sky noises further; this was rejected, the reason given being that this was felt to be domain of academic bodies and not a commercial enterprise. He died at the relatively early age of 44 in 1950. He had been a sickly person all his life and had been rejected by the Army due to his health.

**Grote Reber - USA**

Reber, who was a radio engineer in a factory by day and a radio amateur, W9GFZ, in his spare time, read the paper that Jansky had published about his findings. Jansky's paper surprisingly did not attract much interest from the astronomical fraternity but, as it was first published in a journal for electrical and radio engineers (IRE) this is probably the reason, as astronomers did not know of its existence for several years. Reber had become an amateur at the early age of 15 and had built his transmitter and receiver and earned the Worked All Continents Award (WAC) on radiotelegraphy in a short space of time. He was looking for something equally challenging and, having read Jansky's paper, felt this was the next project for him. Reber is quoted as saying "In my estimation, it was obvious Jansky had made

a fundamental and very important discovery. Furthermore, he had exploited it to the limit of his equipment's facilities. If greater progress were to be made, it would be necessary to construct new and different equipment, especially designed to measure the cosmic static."

Reber was immediately spurred into action. He decided that a parabolic reflector antenna was the best approach, and drew up the design of a suitable piece of equipment. However, when he obtained quotes from contractors to build the dish antenna, it came to more than he earned in a year, hence he set to and built the large parabolic antenna



**Fig 1.4: Grote Reber's parabolic antenna in his backyard at Wheaton, Illinois, USA**



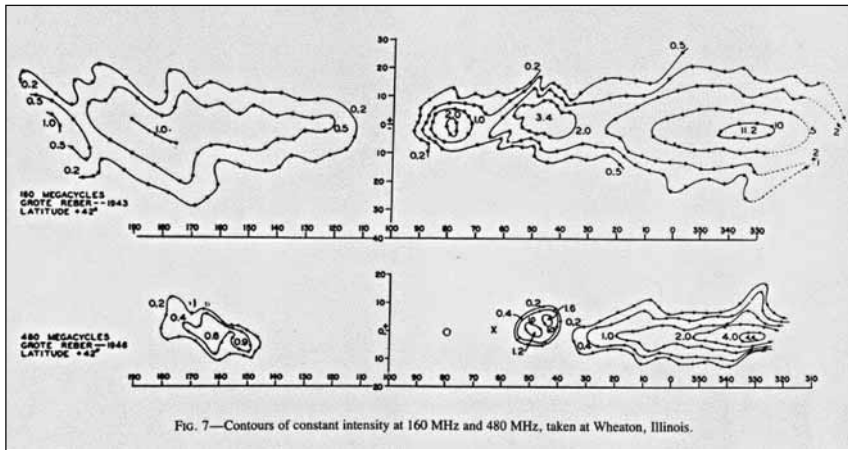

Fig 1.5: Sky Noise plots made by Reber in 1943 at 160 and 440MHz

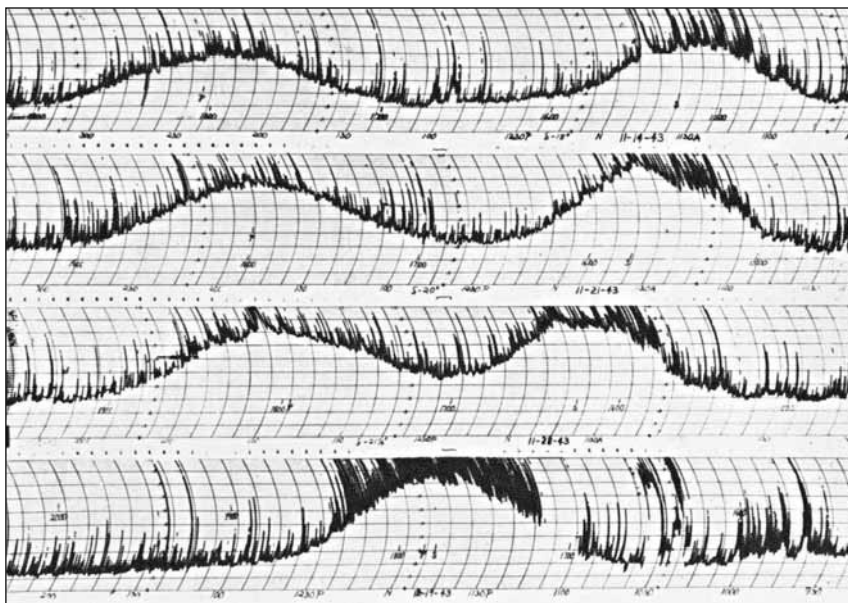

Fig 1.6: Reber's original chart recorder plots of sky noise. The 'spikes' on the traces were caused by automobile ignition interference

31.5ft in diameter (~10m) in his back yard at Wheaton, near Chicago, Illinois, by himself. The reflecting surface was made from 45 pieces of 26-gauge galvanized sheet iron screwed onto 72 radial wooden rafters cut to a parabolic shape. Reber single-handedly made all the timber and sheet iron pieces and, apart from some labour to excavate and cast the concrete foundation, built the entire structure in the space of four months, completing it in September 1937. The total construction cost was \$1300, which was about three times the cost of a new car at that time.

Reber wrote that upon completion: "The mirror emitted snapping, popping and banging sounds every morning and evening due to unequal expansion in the reflector skin. When parked in the vertical position, great volumes of water poured through the central hole during a rainstorm. This caused rumours amongst the neighbours that the machine was for collecting water and for controlling the weather."

**Fig 1.7:** Grote Reber standing next to his preserved antenna shortly before his death. In this picture, the dish has been adapted to be rotatable on a turntable mount, so making it a true Az-El mount



Reber made extensive observations on a wavelength of 9cm ( $\sim 3.3\text{GHz}$ ) and later 33cm ( $\sim 900\text{MHz}$ ) without any success. Finally, after changing to a frequency of 160MHz, Reber detected strong noise sources.

The data collected showed several sources of extra-terrestrial noise and confirmed the findings of Jansky of the Sagittarius source. A crude map of noise sources in the sky was painstakingly built up over a long period, the first of many that were to be made in later years. Reber published his findings in 1938, the first paper on the subject to appear in an astronomical journal [2]. Reber, unlike Jansky, had the foresight to publish his findings in an astronomical journal; if he had not done so, it may well have been many years before its significance was noted.



**Fig 1.8:** Grote Reber with his radio telescope receiver

## Receiver Parameters

### *In this chapter:*

- Limitations to sensitivity
- Typical signal levels
- Noise contribution
- Receiver bandwidth
- Main receiver details
- Modern approach to receivers
- Dicke switching receiver
- IF bandwidth considerations
- Radio flux units
- Radio Horizon
- In-band interference signals
- Radio astronomy frequencies
- Noise performance calculations
- Cryogenic cooling
- Antenna noise temperature
- Effects of sky noise
- Special receiver techniques
- A low-cost amplifier
- Special filtering techniques
- System calculations

**B**y definition, a radio receiver is 'a device which accepts the electrical signal from an antenna and, by a process of amplification, filtering and detection, outputs an intelligible signal'.

In the early radio astronomy systems, the receiver output was not normally used to drive a loudspeaker, as in a normal radio, but was used to drive a meter, chart recorder or oscilloscope. The chart gives the amplitude of the received signal in the same way as the signal strength meter (S-meter) on a communications receiver. Today, the receiver output is digitised via analogue-to-digital converters and either processed in real time by a computer or stored on magnetic media for later study.

In a communications receiver, the signal strength meter is intended for 'casual observation' by the operator to give some indication of the strength of the received signal. In the radio astronomy system, the chart recorder gives an accurate and permanent record of how the received signal varied with time. Time can be translated into various other meanings, for example - in the case of the transit telescope, it can be used to give an exact position in the sky.

The superheterodyne (superhet) receiver is the most commonly used type today, the reason being that the bulk of the amplification and filtering can be performed at a low frequency, the 'intermediate frequency', or IF. The superhet uses a process of frequency mixing to bring the input signal to a lower frequency.

At this lower frequency the amplification and signal filtering to reject out-of-band noise and other interfering signals are more easily performed. Hence, it is possible to achieve the very high signal amplification required and good selectivity without the difficulty of instability that could occur at the higher input frequency.

## LIMITATIONS TO SENSITIVITY

In receiving systems, the concept of signal-to-noise ratio (SNR) is used. The signal is the wanted output and the noise, by definition, is either internally-generated in the receiver or externally-generated by an interfering source. Noise, therefore, by definition, is any signal other than the desired one. In a radio telescope receiver, the wanted signal is extremely weak for most cases and is often broad-band; it is not a coherent single carrier - it resembles noise, but it may have a frequency dependence about a particular frequency, for example the Hydrogen Line at 1420MHz.

The limitation to the ultimate sensitivity of the receiving system is the noise performance of the receiver's first amplifier stages, the front-end or low-noise amplifier, LNA. For maximum sensitivity, the front-end amplifier stages need to have the lowest possible noise figure with adequate gain.

As the first stages in a receiver effectively determine the overall receiver sensitivity, it is important to strive for the lowest noise figure in the early RF amplifier stage(s).

Contributing factors to the overall receiver noise figure include the transmission line and connectors that connect the antenna terminals to the first amplifier stage. This can be a large contributor to the overall noise figure if lossy coaxial cable or connectors are used.

In a normal radio telescope system, the LNA would be connected directly to the antenna feed-point, reducing the insertion loss of any cable to essentially that of the connector losses.

The VSWR mismatch between the antenna and the LNA can add another fraction of a dB to the noise figure. In many cases the LNA will present a severe mismatch to the antenna feed point in order to obtain the optimum noise figure. A VSWR mismatch of 10:1 or more is not uncommon for certain types of LNA.

## TYPICAL SIGNAL LEVELS FOR ASTRONOMY

It is as well to appreciate that the sort of sensitivity required is greatly in excess of even a very good communications receiver. In order to understand the very small signal levels involved it is necessary to get a benchmark against a typical radio telescope receiver and a commercial two-way radio receiver operating at VHF. A typical sensitivity figure often quoted for a commercial two-way radio VHF receiver is  $0.25\mu\text{V}$  for 12dB SNR. In a  $50\Omega$  system this is -115dBm, or a minimum discernible signal of  $115 + 12 = -127\text{dBm}$ . By comparison, the signal to be expected with an average radio telescope is approximately -190dBm; in many cases, the lower limit will be of the order of -260dBm when additional signal processing and long-term integration techniques are employed. This level of signal is very much weaker than a system for Moonbounce (EME).

To put the signal levels into perspective, it is useful to calculate the path loss for some strong noise sources. Taking our Sun and Cygnus-A as two examples. The Sun is situated at  $149.6 \times 10^6$  km from the Earth and Cygnus-A is approx.  $550 \times 10^6$  light years away. A light year is  $9.6 \times 10^{12}$  km, so Cygnus-A is  $5.3 \times 10^{15}$  km distant.

Using the path loss calculation formula in Chapter 2, we can calculate the attenuation the signals suffer. If we observe on 144 MHz, the value for the Sun is 239 dB and for Cygnus-A it is 390 dB. Assuming our 144 MHz antenna has a gain of 30 dB and the Sun radiates a signal of 1 MW, the expected signal level at the LNA input will be -119 dBm. In practice, the observed Sun noise can be as much as 10 dB above the receiver noise floor for a quiet Sun and as much as 20 dB above the receiver noise floor for a disturbed Sun when solar flares or sun spots occur.

For Cygnus-A using our 144 MHz antenna of 30 dB gain, assuming the power radiated is 1 GW, the expected signal level will be -240 dBm. However, we know from the received signal of Cygnus-A that the power radiated is about 10 billion TW ( $1 \times 10^{22}$  W). [1 terawatt (TW) =  $10^{12}$  W]

## NOISE CONTRIBUTION

### Image Noise

An important factor in superhet receiver design is the noise power contained at the image frequency. Due to the mixing of the input signal and the LO to produce a lower IF, two possible input signal frequencies can produce the same IF for a given local oscillator frequency. One is the wanted frequency and the other is the image frequency. In a receiver down-converter using low-side LO injection, the upper of these two is treated as the wanted frequency and the lower one as the image frequency.

If the image frequency is not sufficiently suppressed by either filtering in the RF amplifier stages or by some other technique, the image noise, if it is of equal signal level to the wanted signal (this is the case for pure noise caused by resistive means), will cause a 3 dB (50%) degradation of the SNR. In many cases, due to interfering sources, the image noise power can be much greater than the wanted signal. There is, however, a trade-off to be made between the sensitivity gained by image noise filtering and the noise figure degradation caused by the loss in the first filter section before the amplifier stage.

It is possible to select too narrow a filter in an effort to suppress image noise; hence it will have appreciable loss. It is as well to remember that any loss before the first amplifier device will add directly to the noise figure of the amplifier. Whereas the receiver SNR may be improved by reducing the image noise component, it may well be that this is more than negated by the noise figure degradation caused by the image filtering loss. Low-noise amplifiers have little or no filtering before the active amplifier device in order to minimise the noise figure.

It also is prudent to select the local oscillator frequency to avoid potential interfering signals at the image frequency. For each input signal and IF combination there are two possible local oscillator frequencies that may be used. Often, for ease of construction, we would wish to choose the low-side injection in preference to high-side injection. Choosing low-side injection means that the multiplication for the local oscillator chain is less than for high-side injection

and the LO frequency is consequently lower. But it may be that the image frequency potentially contains strong interfering carriers. For example, if 144MHz was the input frequency and the IF is 21.4 MHz then the choices of LO are  $(144 - 21.4) = 122.6\text{MHz}$  or  $(144 + 21.4) = 165.4\text{MHz}$ . The image frequencies would be 101.2 MHz for low-side injection and 186.8 MHz for high-side injection. The choice of low-side injection places the image in the middle of the FM broadcast band where strong interfering signals will be present. The choice of high-side injection places the image within the television broadcast Band III, where strong interfering signals at the image frequency may also be present. For these two cases the image rejection would need to be in excess of 100dB to prevent interference. By selecting a different IF, and hence LO, the image can be moved into a quieter portion of the spectrum.

**Image Rejection Mixers**

An alternative to image signal rejection by filtering is the use of an image-rejection mixer which is a common technique used at microwave frequencies where filtering is often difficult. An image-rejection mixer (IRM) consists of two double-balanced mixers, two 90° phase shifters and a 0° power combiner. By using this technique, the unwanted image band of frequencies is cancelled out. A block diagram of a typical IRM is shown. Today for microwave applications the mixers and phase shifters are often constructed in chip-form directly on an IC.

The conversion loss of an image-reject mixer is usually only a fraction of a dB higher than a normal type; in some cases it is a little less than a conventional mixer. However, one important fact to be aware of about image-reject mixers is that, although they reject coherent carriers at the image frequency, they do not reduce the image noise, which is our primary concern. So, although we can utilise an image-reject mixer, we will also still need some image filtering to improve the system noise figure.

In practice, if the image signal noise power is reduced by approximately 10dB, the image noise contribution becomes insignificant. It is possible to achieve 25dB of image suppression to coherent carriers in an image-reject mixer without introducing significant losses and, in addition, by using wide-band-low-loss filtering in the RF input, a suppression of 40dB or more is achievable. Only in the case of the image frequency containing a strong coherent interfering signal would any greater suppression be required. Here it is preferable to utilise a notch or trap filter tuned to the image frequency that introduces minimal loss at the signal frequency. High-performance HF communication receivers typically have image rejection figures of 70dB to 100dB due to input filtering alone.

Another way around the lossy image filter problem is to use a double-supernet with a very high first IF, as the image frequency is situated at a frequency of twice the IF away from the wanted frequency. This, for a low-frequency input signal (in the HF or VHF range), will entail firstly mixing the signal

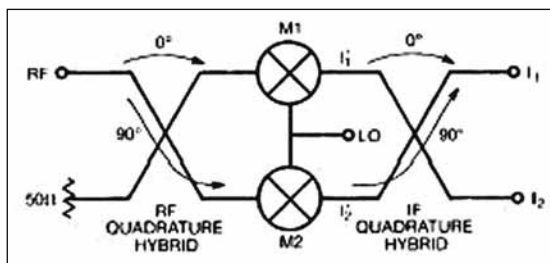

Fig 3.1: Image rejection mixer diagram

up to a higher frequency of typically 1GHz, then a second narrow-band down-converter is used to bring the signal to a normal IF of typically 70MHz or less. The input amplifier band-pass filter can then be replaced with a low-pass filter, rolling off in response a little above the receiver frequency. Low-pass filters generally have lower insertion loss than a narrow-band symmetrical band-pass filter. The filter losses after the mixers at 1GHz and 70MHz are relatively small and can be tolerated in such a system.

Equipment for measuring noise figure will, if the receive mixer is not preceded by an image filter, give an optimistic noise figure due to the image noise adding to the wanted signal.

If the receiver consists of a wideband LNA (no image filtering) and a single double-balanced mixer, the noise figure measured will be 3dB less than the actual figure. Noise figure measurements need to be done using a single-sideband technique and not a double-sideband type, which an unfiltered mixer with image noise contribution inherently gives.

## LOCAL OSCILLATOR NOISE CONTRIBUTION

The assumption for optimum noise performance is that the local oscillator signal is a perfect sinusoidal carrier of zero bandwidth, in the real world, this is not the case. If the local oscillator is noisy, either in amplitude or phase and contains significant noise power or other spurious response at the image, the noise will be mixed on to the wanted IF signal. This is known as reciprocal mixing, and will cause degradation of the signal. Receiver local oscillators need to have extremely low noise performance for radio telescope duty in order to maximise the sensitivity. A crystal-controlled oscillator is usually far superior to a synthesised oscillator. If the radio telescope is required to operate on several different frequencies, a local oscillator, mixer and LNA are required for each new band. This imposes a problem with switching the LNAs with minimal losses. Often the LNAs are mounted at the antenna feed-point and, because any form of switching relay introduces a slight but unwanted loss, changing frequency band often requires a technician to climb the antenna and physically disconnect the old antennas and LNA and reconnect the new antenna and LNA by hand. This can be a time consuming process, not to mention the potential hazards involved.

Jodrell Bank Mk1 originally got around this problem by stationing a technician at the dish in a weatherproof cabin slung under the dish centre. The cabin pivoted on a hinge so that it was always vertical. A lift from the ground allowed quick entry into the cabin.

This then involved a short climb through a trap door to the dish floor and to the feed-point box, via a ladder fixed to the tower, to make the changes. Even so, the climb was some 20m and at night, this can be quite daunting, especially as the bottom of the dish is already about 80m in the air.

To make this work, the dish needed to be driven to the zenith (the dish pointing directly upwards) each time the LNA needed changing. The local oscillators were originally contained in the technician's cabin and these then fed the resulting 1st IF to the main receiver by a long coaxial cable to the central control room some 200m away.

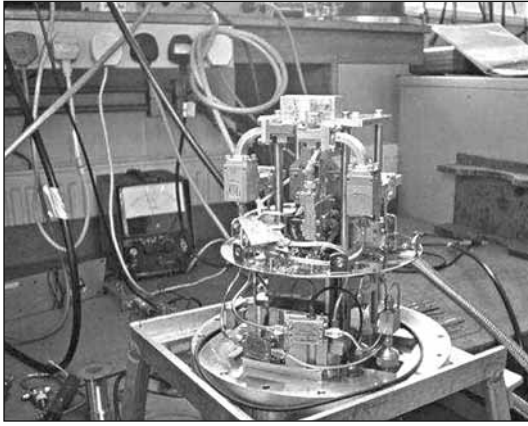

**Fig 3.2: 20GHz liquid-helium-cooled receiver front-end under development at Jodrell Bank Radio Observatory. (Photograph: J Fielding 2004)**

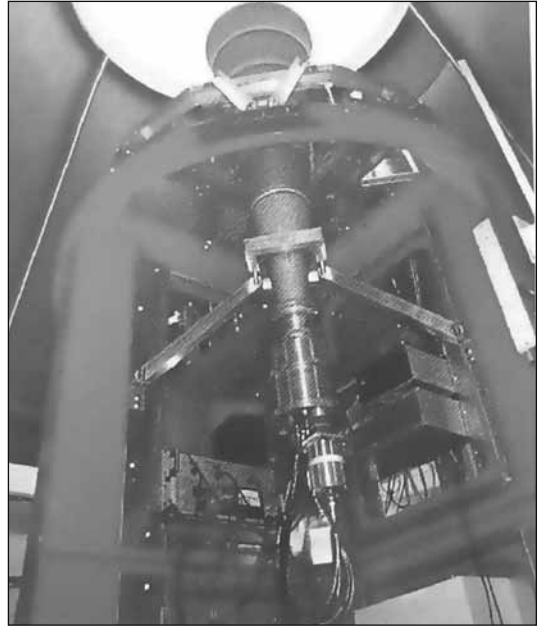

**Fig 3.3: A receiver carousel fitted to a cassegrain-focused antenna. (Photograph courtesy of Jodrell Bank Observatory)**

With the advent of liquid helium cooling of the LNAs this became an impractical method and the availability of better coaxial relays with much lower insertion losses meant that all the changes could be done remotely from the control room. Today the preferred technique uses the LNA and mixers incorporated into the 'front-end' module, all of which is cryogenically cooled. The various front-ends are arranged in a carousel that can be rotated to bring the required one to the focal point of the dish.

Currently (2005) the Jodrell Bank Mk1A radio telescope does not have a carousel fitted due to the limited space in the focus box. On the author's last visit in September 2005, the four-channel Hydrogen Line receiver was doing double duty as a pulsar and Hydrogen Line receiver.

## **BROAD-BAND NOISE AND NOISE POWER**

As the noise power contained in a 1Hz bandwidth for a particular condition is constant then the same follows for other bandwidths. Suppose we measure the absolute level of power in the 1Hz bandwidth - let us say it is  $1\mu\text{W}$  in a  $50\Omega$  impedance for convenience. If we now use a measuring bandwidth of 1kHz, the level of power we expect to measure is 1000 times as high, being 1mW. (You can imagine this is 1000 windows stacked side by side, each one is 1Hz wide, each of which lets  $1\mu\text{W}$  pass. The total amount of power is therefore the sum of all the windows.) This is an increase of 30dB. If we use a 1MHz measuring bandwidth, the power level will be 1000 times higher still, it will be 1W. Therefore it is much easier to measure the power in a wide bandwidth than it is in a very narrow bandwidth. As the level of noise power in a 1Hz bandwidth is likely to be very small, it is easier to use a wider measuring bandwidth and then calculate the effective 1Hz bandwidth figure. In fact, we can choose any suitable bandwidth and then work back to find the 1Hz-bandwidth value. Everything can be scaled to a new bandwidth.



## Assembling a Station

### *In this chapter:*

- |   |   |
|---|---|
| <input type="checkbox"/> Basic receiver components        | <input type="checkbox"/> Antenna positioning co-ordinates |
| <input type="checkbox"/> Choice of frequency band         | <input type="checkbox"/> North and South Pole correction  |
| <input type="checkbox"/> Some basic receiver requirements | <input type="checkbox"/> A simple C-band radio telescope  |
| <input type="checkbox"/> Permanent recording techniques   | <input type="checkbox"/> What you will be able to observe |
| <input type="checkbox"/> Feed line considerations         | <input type="checkbox"/> Radio object catalogues          |
| <input type="checkbox"/> System budget calculations       | <input type="checkbox"/> Besselian and Julian years       |
|   | <input type="checkbox"/> Object naming system             |

**I**f the reader has digested the various sections prior to this, it should be relatively simple for him to work out what is required to assemble a station to meet his needs. Before we can specify the parameters of the various components, we need to decide on what the station is going to be capable of and the types of objects it will be able observe. It could be that an alternative use for the station is to be able to work EME, in which case the system could be designed to be dual-purpose with little extra expense.

### **BASIC RECEIVER COMPONENTS**

In any station we will need certain items; these we can largely break down into logical parts.

- An antenna of some type,
- a low noise amplifier,
- a length of feeder between the antenna and the receiver,
- a receiver,
- some means of recording the received signals in a permanent way.

### **CHOICE OF FREQUENCY BAND**

It is as well to be aware of the 'radio window' limits before choosing a suitable frequency band. The portion of spectrum from approximately 50m (6MHz) to about 1mm wavelength (300GHz) is the width of the window, therefore it would be pointless to attempt measurements on, say, the 80m band, as the radio waves would be unable to penetrate the ionosphere, except for limited periods during the night. The exact upper frequency is difficult to fix at present, but up to 1mm (300GHz) has been used and the likely upper limit may be higher than this.

The requirements for each type of system will rely heavily on certain factors. For example, if the desire is to receive meteor trail signals, we can state that the antenna needs to have a fairly broad beamwidth. Hence, it will be a limited-gain antenna. The frequency needs to be fairly low, not exceeding about 300MHz, and the receiver needs to have a high gain with a fairly narrow IF bandwidth.

Because the amateur VHF bands are somewhat harmonically-related and limited, we are left with three choices for the frequency band. Of these, 50MHz (6m) is a popular choice, but the antenna size is quite large for a reasonable amount of gain. The next available band, but not in all countries, is 70MHz (4m), where the antenna size is a little smaller. The final choice would be 144MHz (2m) where the antenna size is even smaller than the other two. In some countries, amateurs are able to use 220MHz, but this is starting to get a little high for reliable meteor-trail reflections.

The type of reflection to expect also varies with frequency. At 6m and 4m, the majority of reflections are from under-dense trails, and the reflections last for a fairly long time, often being many pings occurring one after another in rapid succession, and then they are often referred to as 'bursts'. The length of a burst can be several seconds under favourable conditions, allowing SSB operation. At 2m and above, the predominant mode is from over-dense trails and then the bursts are much shorter and more like discrete pings. At 70cm, the success rate drops to less than 10% of that of 2m, so 70cm is much more difficult in this respect.

The next factor depends very much on physical location. In an ideal situation, the station would be situated in a remote part of the countryside away from other dwellings, heavy industry and overhead power lines. Few amateurs are in this fortunate position. If you live in an urban environment with a lot of other properties close by, the level of man-made noise is likely to be high. Hence, 50MHz or 70MHz would not be as good a choice as 144 MHz.

In the author's case, the almost-ideal situation exists, at least on paper. The station is situated on top of a mountain in a rural environment with almost a 360-degree horizon.

When I was looking for a new property, this was an important point because of the amateur radio hobby. However, this is not ideal. Although the clear take-off in most directions is very good for VHF DX working, it is also a disadvantage due to other factors. It is a region of Kwa-Zulu Natal known as the 'Valley of a Thousand Hills'; there are more than 1000 hills in fact.

Nearby hills are densely populated with cell-phone, two-way radio, television and FM broadcasting stations. Because of this, the level of RF pollution is quite high and limits the ultimate sensitivity of any receiving system. Intermodulation products from the nearby TV and FM broadcast transmitters cause in-band signals to appear in 2m.

After the move from my previous location, it was found that the LNA used for the 2m EME station was suffering excessive overload because of the strong local signals. This required the design and construction of a new LNA that had better signal-handling and notch filters to eliminate the problem. However, the inter-modulation signals from the broadcast transmitters could not be eliminated, as they were generated in the transmitters.

For radio astronomy, we need a clear view of the sky, but not at the horizon in most cases. In order to screen the antenna from interfering signals, it is often beneficial to mount the antenna low down. In the case of meteor trail propagation, we need an antenna mounted only a few metres above ground level and pointed up at an angle of about  $40^\circ$  to  $70^\circ$ . It is necessary to be able to alter both the azimuth and elevation from time to time, but this can be a manual operation and, with the antenna close to the ground, is not difficult.

If the intention were to receive signals from deep-space objects (eg Sagittarius in the Milky Way), a higher frequency would be an advantage. The antenna would need to be fully steerable in azimuth and elevation, and a precise knowledge of where in the sky to point the antenna. This could be done with computer software or from celestial charts. In many cases, due to cloud, the sky will not be visible (occluded) so a visual sighting cannot be relied upon.

Suitable frequency bands would be 144, 432, 1296 or 2300MHz. The higher the frequency, the narrower beamwidth it is possible to achieve with a reasonably-sized antenna. Either a Yagi array or a small parabolic reflector would be suitable for 432MHz upwards. For 144MHz we are stuck with using Yagi-type antennas, due to size constraints. An advantage of a higher over a lower frequency is the sky-noise due to the atmosphere. At high frequencies it falls to low values and makes weak radio-star detection easier.

The disadvantage of choosing a higher band is the extra path-loss attenuation suffered by the higher frequencies, both from atmospheric attenuation and normal free-space loss, and the difficulty of obtaining a sufficiently-low system noise figure, due to limitations in available low-cost amplifier devices. A good compromise would be either 432 or 1296MHz, as here it is relatively easy to construct low-noise amplifiers with suitable noise figures. It should be obvious that we need to choose a portion of the band where no activity normally takes place; it is a bit pointless trying to listen on a repeater output channel or a beacon frequency!

## **SOME BASIC RECEIVER REQUIREMENTS**

The receiver needs to be carefully considered. By placing a suitable low-noise amplifier at the antenna, we can effectively determine the system noise figure so the average commercial multi-mode transceiver is probably adequate. It may well be that you already have a VHF or UHF transceiver that covers the band selected. This is not always the best option as the IF filter fitted may be too narrow a bandwidth for the type of sensitivity we require. Often the best option is a low-noise crystal-controlled down-converter and a tunable HF receiver with a variety of IF filter bandwidths. It is easier to modify an HF receiver than a complex multi-mode VHF/UHF transceiver. FM transceivers are not at all suitable unless the IF can be replaced with an amplitude detector. In many cases, an older type communication receiver can be purchased at a reasonable cost. The modifications are not difficult to perform and many articles have appeared in various publications detailing these.

Another factor is that we do not want automatic gain control (AGC). The receiver gain needs to be controlled manually for the best results. It is as well to appreciate that the signal level variation between not seeing a radio star and seeing a strong radio star will only be of the order of a few decibels at best. The

task of detecting a weak source is difficult, even with sensitive equipment. If the AGC is continuously changing the receiver gain, because of small bursts of man-made noise, the chances of seeing a small increase in noise from a distant radio star are well-nigh impossible. The human ear is not a good detector for small changes in signal level. Often, even with a well-trained operator, it is difficult to detect less than a 3dB change in audio level. The detection needs to be done visually, with an oscilloscope, meter or a pen recorder. The receiver S-meter is virtually useless for this task, as it is far too insensitive to very small signal-level changes. In most receivers, when manual gain is selected, the S-meter ceases to work.

One technique used by meteor scatter operators to determine meteor activity, is to listen on the frequency of a distant beacon. At most times this will be either just on the noise floor or below it. To resolve a weak carrier requires a beat-frequency oscillator (BFO), which turns the received carrier into an audible tone. When a meteor trail occurs the beacon signal reflected off the trail is much stronger in level and the receiver outputs a strong audio tone while the trail is acting as a reflector. The duration of most meteor trail echoes is only a fraction of a second in most cases, and this causes the signal to sound like a 'ping'. By counting the number of pings occurring in a minute, you get a good idea of the meteor shower intensity. Low-intensity sporadic showers, which occur throughout the year, give ping rates of one or two in five minutes. In intense showers the pings can be as high as 1000 in a minute, making an almost continuous means of propagation which can be used for two-way contacts - meteor scatter (MS).

The receiver bandwidth required is the same as for CW; approximately 300Hz or narrower can be used. The narrower the IF the better, and often extra external signal processing will give good rewards. In the author's case, an external 40Hz bandwidth active audio filter is used which gives about 10dB SNR improvement on weak signals, such as EME.

## PERMANENT RECORDING TECHNIQUES

For the sake of accurate data collection, some type of automated system is the best option. Whereas most people are capable of keeping notes of activity in a notebook, the events often occur too quickly for an accurate account to be made. It is a good idea to get into the habit of having a notebook as a rough record as sometimes systems crash and you would be left with no data in such an event.

In the case of meteor trail reflections one of the simplest and lowest cost, is a cassette recorder. If the receiver audio is fed into a cassette recorder, the pings can be recorded and later played back to count the number of pings in a given time. Today, with the advent of computers, another method is to use a .wav file to record the data via the computer's soundcard. This has the advantage that, with suitable software, the pings can also be displayed graphically at a later time for more precise analysis and time stamped by the computer real-time clock. Another benefit is that recordings can last for days and only rely on the size of disk storage available. The downside is that computers can generate broad-band interference, which can degrade the receiver performance.

If the resources run to it, a chart recorder is a nice way to capture data. It has the advantage that, with a long enough piece of paper, the records can represent several days with a slow enough rollout of the paper. (Professional chart recorders have

a variable speed drive.) The chart recorder paper is normally incremented with divisions and vital information, such as start and stop times, and can be annotated manually. The author used this technique when studying signal enhancement at 1GHz during sunrise and sunset, to explore the path loss between two distant sites. At sunrise and sunset, the signals showed substantial improvements over the average recorded during the daytime or nighttime. This knowledge allowed the author to set a new personal best record during a contest on 23cm.

## FEED-LINE CONSIDERATIONS

As with most sensitive receiving systems, you can never have too good a coax cable for the feed-line. In practice, as long as the masthead pre-amp is of sufficiently low noise figure and has adequate gain, more modest types of cable can be used. Often a type such as RG-213/U will suffice. It is preferable to use a type of cable that is double-shielded (RG-214/U) to prevent any interfering signals from leaking into the receiver. You will need to do the system calculations based on the cable length and predicted loss to establish if the cable loss is acceptable for the overall system

## SYSTEM BUDGET CALCULATIONS

Some years ago, the author wrote a computer program in BASIC for calculating the path losses and overall SNR for EME (see box overleaf). Using this, and changing various system parameters, it was easy to see where the weak links in the proposed system were.

### An Example of EME System Requirements

Using the software, consider a couple of system permutations to see where the weak points are. We will assume that 2m EME is the requirement and we have a 100W transmitter with average feed-line cable.

The basic system parameters are

Transmit power	100W
Transmit feed-line	1dB loss
Receive feed-line	1dB loss (the same cable is used for Tx and Rx)
Transmit antenna gain (dBd)	22dB - 4 x 16-element Yagis
Receive antenna gain (dBd)	22dB (the same antenna is used for Tx/Rx)
Antenna noise temperature	300K (pointed at a quiet part of the sky)
Receiver noise figure 3dB	(no masthead LNA)
Receiver bandwidth	300Hz (normal CW filter)

The calculated SNR is -10dB.

We will not hear our own echoes under these circumstances. The antenna is about the maximum we can erect, so we have to make alterations elsewhere. The sky temperature we have no control over and we have to accept this value. An obvious solution is to run more transmit power, this is an expensive option, but justifiable. So let us spend some money on a bigger amplifier to increase the transmit power to 400W and leave everything else the same.

The new calculated SNR ratio is -4.0dB (an improvement of 6dB, which is what you would expect with four times the power). This is a big improvement, but we will not expect to hear our own echoes. Stations such as W5UN will be

## 50MHz Meteor Radar System

### *In this chapter:*

- Low power transmitter stages
- Power amplifier
- Power Supply
- Grid bias
- Transmitter control circuits
- Final stage pulse shaping
- Grid bias stabiliser
- Control generator
- Clock generator timing diagram
- Receiver design
- Post-detection processing
- Interconnection
- System improvements
- Antenna combiner
- Low-noise masthead amplifier
- Harmonic low-pass filter
- Circuit diagrams
- Alternative antenna array

**T**he author is involved with the study of the Southern Hemisphere sporadic meteor showers. These occur randomly throughout the year at low rates. In order to study them, it was necessary to modify some of the station equipment and build some new receiving equipment. The initial study is being carried out at 6m; at a later date it will be extended to 4m and 2m. The intention is eventually to have two systems running in parallel to assess the reflections on two widely-separated frequencies and try to correlate the results.

Amongst the author's old equipment was a dual-band linear amplifier for 2m and 6m built many years back that uses two QQVO6-40 valves. This was one of many 'doppelganger' types made by local amateurs to reduce the bench space and power supply requirements when operating on the lower VHF bands. The amplifier can operate on either 6m or 2m using a common power supply, but only one band at a time. This was mothballed when better equipment was constructed. The 6m section of the amplifier uses a QQVO3-10 as a driver stage, as the home brew 6m solid-state transverter used at the time produced only approximately 250mW. The fully-saturated output power is about 250W. This amplifier uses the author's screen and grid solid-state stabilisers published some years ago. With minor modifications, the 6m amplifier will also work on 70MHz. The author's newer 144MHz EME amplifier uses a pair of 4CX250Bs, which are capable of 1500W output, if needed.

As it wasn't necessary to build everything from scratch this saved a lot of time and effort.

The system calculations were performed with an RF simulation software package, where the gain, noise figure and intercept point for each stage are entered to identify the critical areas in the design. Having settled on a practical receiver and transmitter line-up, design and construction began of the new items. These were:

- Transmitter oscillator and switching circuits
- Transmitter control and pulse-shaping circuits
- Receiver front end and mixer
- IF amplifier, filter stages and detector
- Post-detection filtering and display driver
- Antennas
- LNA for receive antennas

## LOW POWER TRANSMITTER STAGES

The transmitter uses valves for all the stages. A solid-state design is possible but involves a lot more effort. As the writer had a good stock of valves it was decided to use these. Another factor favouring valves is that high gain and high power are easy to obtain. The transmitter consists of just three valves to develop an output power of over 300W PEP. A further valve is used in the modulator stage.

The biggest problem with a design such as this is that the transmitter oscillator has to run all the time, it is impractical to switch off the oscillator during the receiving period. If the oscillator runs at the final output frequency, it will cause an interfering signal that the receiver will pick up and see as a constant signal. Therefore, it was decided to use a low-frequency crystal oscillator that was then multiplied to the final frequency. In the 6m version, a crystal at 0.25 of the final frequency is used. The oscillator (exciter) stages are built on a chassis separate from the main power amplifier and are contained in a well-shielded box to prevent radiation of interfering signals.

The oscillator consists of a Colpitts oscillator using a fundamental frequency crystal with a 30pF load capacitance. The exact frequency will depend on the final frequency required. In the author's system, a 12.675MHz crystal was ordered. The valve used is a 12AT7, which is a twin-triode. Other valves are also suitable, E88CC, 6J6 etc, or even two separate triode or pentodes. The anode circuit of the oscillator has a tuned circuit resonant at twice the crystal frequency (~25MHz). This is then loosely coupled via a 22pF capacitor to the grid of the multiplier half of the valve. The voltage developed across the multiplier grid is approximately 2 to 3Vp-p. This is adequate to drive the multiplier to full output. The multiplier also has a resonant anode circuit that is tuned to the output frequency of 50MHz. The two stages act as a doubler-doubler circuit with good filtering of unwanted oscillator products. The 12MHz products are more than 60dB below the carrier and are further attenuated in the following power amplifier stages to more than 80dB. A possible option is to use a crystal at 1/3 of the final frequency; the oscillator anode circuit would then be resonant at the crystal frequency, and the multiplier would then act as a tripler stage. The output from the multiplier is link coupled to 50Ω and fed via a coaxial cable to the power amplifier chassis. The anode supply of the oscillator is derived from the main 300V supply with two 75V, 1W Zener diodes connected in series to give a stable 150V supply for good frequency stability.

The multiplier stage is fed with a pulsed HT supply that is provided by the modulator stages. This voltage is only applied when the transmitter is required to provide an output, hence the drive to the following stages is on only when a pulse is required.

If the multiplier stage was fed with a continuous supply a problem arises. This is the generation of a strong carrier during the receive period which would effectively mask any echoes.

If the driver stage only has a limited attenuation when its screen supply is turned off, there would be a small constant signal driving the final stage. This causes a 'spacer carrier' which is very difficult to get rid of, and would block the receiver.

In practice, the final stage acting as a pulse modulator has an attenuation range of approximately 30dB because of capacitive feed-through in the valve. By switching off the multiplier and driver during the receiving period, the attenuation increases to the order of about 80dB. With adequate attenuation between the transmitter and receiver, this is acceptable.

When viewed on the spectrum analyser, the carrier suppression during receiving periods is over 90dB. The multiplier stage gives approximately 30dB suppression; the driver also gives the same sort of suppression, and the PA supplies about 20dB of suppression.

Because valves are used with high-Q tuned circuits, the unwanted products from the multiplier are well suppressed. The following power amplifier stages also have considerable discrimination to 'off frequency' products. The only significant products detectable at the output of the final stage are harmonics of the 50MHz signal.

All other products are more than 80dB down. To achieve this with transistors would be much more difficult and would require a greater number of stages. Valves are also far more tolerant to mismatch caused by antenna VSWR, and cope with over driving more easily.

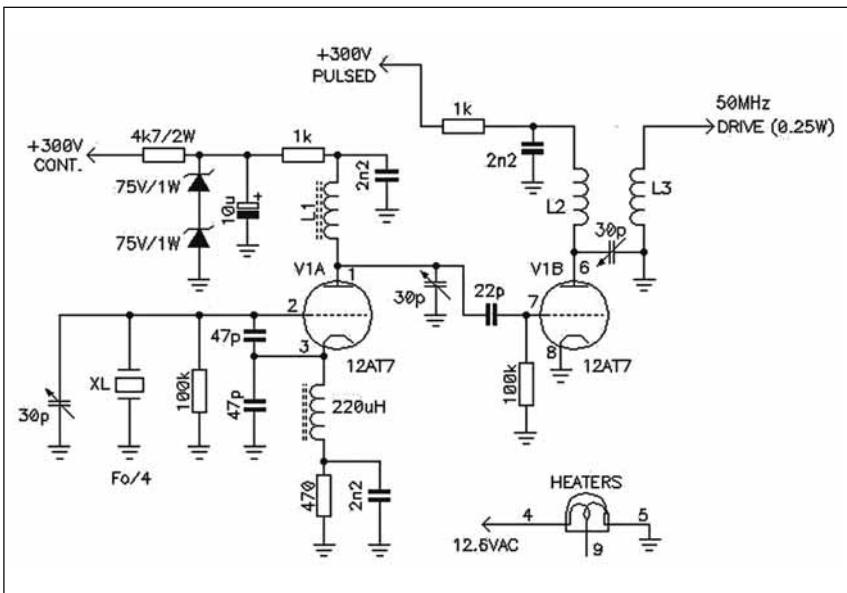

Fig 7.1: 6m meteor radar low-power transmitter stages



The inductor, L1, in the anode of the oscillator is wound on a toroidal ferrite core and is resonated with a 30pF trimmer to 25MHz. The inductor, L2, in the anode of the multiplier anode is an air-wound coil wound on an 8mm mandrel and also tuned with a 30pF trimmer. In the author's case these trimmers were Philips 'beehive' types rescued from old two-way radio transmitters. The 30pF trimmer across the crystal sets the exact operating frequency.

The choice of transmit frequency was so as to place it far away from the normal communications portion of the band. Depending on which band plan you follow will determine what frequency is suitable. In the author's case, the frequency of 50.7MHz was chosen because no activity normally occurs there. (In South Africa the amateur portion of the 50MHz spectrum extends from 50MHz to 54MHz, but only the bottom 2MHz is exclusively allocated to the amateur service. The portion between 52MHz and 54MHz is shared with commercial users.)

## POWER AMPLIFIER

The dual band amplifier follows standard designs to be found in many amateur publications. Some pictures of the amplifier are shown here. The double-tetrode stages are operated in push pull to achieve low second harmonic generation. An external low-pass harmonic filter is used. If the driver is not required, the grid-input power required is approximately 6W for Class-C. This could be provided by a 10W transistor stage.

## POWER SUPPLY

An old Yaesu FT-200 HF transceiver power supply is used to power the amplifier. This has HT taps for up to 850V. For this application, it is quite safe to use as much as 1200V for the PA stage anode supply as the duty cycle is low. The FT-200 PSU also supplies +350V, +175V, control grid supply of -100V and the heater supply of 12.6VAC.

## GRID BIAS

For best efficiency in Class-C, the control grid of the QQVO6-40 needs to be supplied with a voltage sufficient to cut off the valve when no drive is applied. For the more normal Class-AB1 operation, the grid bias is adjusted to provide

approximately 35mA of standing anode current with no drive applied. This normally requires a grid voltage of -35V to -45V, depending on the anode and screen voltage and the emission of the valve. Older valves have lower emissions and hence the grid voltage will be

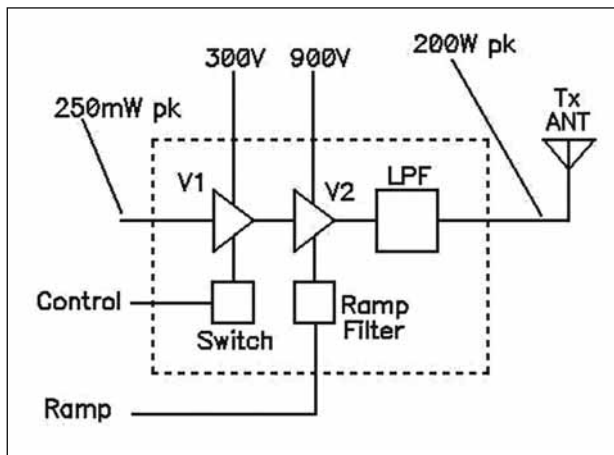

Fig 7.2: 6m meteor radar power amplifier

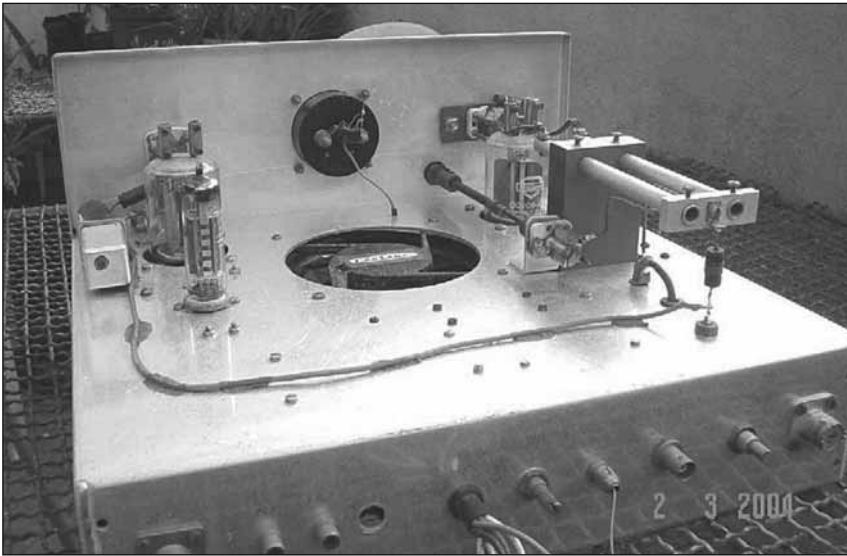

Fig 7.3: Rear view of the 6m and 2m dual-band power amplifier. The 6m portion is on the left. The QQVO3-10 driver valve is located behind the QQVO6-40 final stage. The cooling fan draws air from above the chassis and pressurises the lower portion of the chassis. The air is forced over the glass envelopes of the valves via the cut-outs for each valve base

closer to -35V than the higher value. For Class-C, the grid voltage is higher. The amplifier anode current is adjusted with the bias control, with no drive applied, until the anode current just shows zero. With approximately 850V on the anode and 300V on the screen grid, this will be a grid voltage of -50V for a good valve.

Another important factor about the grid bias, which is largely misunderstood by many amateurs, is that it must be a very 'stiff' supply. If the application of drive causes the grid voltage to vary, the operating point of a triode or tetrode will also vary - poor results being the outcome.

The sort of stiffness required is very high - in an SSB linear, the variation of the grid bias causes severe inter-modulation products to be introduced. A variation of only 1V is sufficient to shift the operating curve into a more non-linear region.

Only one band can be used at any time because the screen and grid regulators are common to the two valves, as is the metering. The 6m section uses a lumped anode network: the 2m section uses a 'linear line' anode network. The 2m section develops approximately 150W PEP and has been used to contact W5UN on EME.

The pictures of the amplifier overleaf show it with the outer covers removed. The top cover is a U-shaped aluminium folded section. The bottom cover is a flat aluminium plate, as is the back plate. These covers make it reasonably 'RF tight', except for the necessary cooling air slots punched in the top and back cover.

## TRANSMITTER CONTROL CIRCUITS

The transmit control circuitry is driven by the main Control Generator and part of it controls the screen supply to the driver valve and the anode of the multiplier valve. During receive, this supply is switched off.

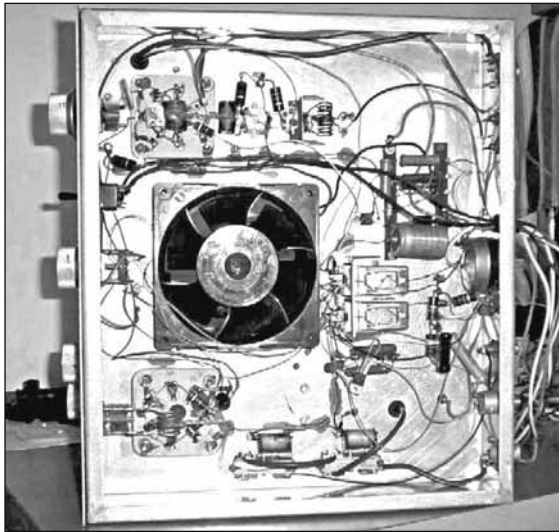

**Fig 7.4:** Underneath view of the dual-band amplifier. The 6m section is at the top



**Fig 7.5:** Close-up view of the 6m output network in the dual-band amplifier

The drive signal is the blanking pulse that also switches off the receiver IF during transmit. Transistor TR1 and TR2 can be almost any low-power npn transistors such as a BC107 or 2N2222. TR3 is a low-power pnp such as a BC327 or 2N2907. The totem-pole stage consisting of TR2 and TR3 ensure rapid switching of the high gate capacity MosFETs. TR4 and TR5 need to be high-voltage MosFETs; IRF-840s rated at 500V were used mounted on a small heatsink.

**Note:** The diodes between the MosFET gates and ground must not be omitted, as they prevent damaging negative voltage spikes generated by the fast switching of the high voltage. The supply voltage must be greater than 10V and up to 15V maximum.

The pulse driving this circuit is twice the length of the final transmit pulse, because the shaping circuit delays the high voltage supply to the PA valve screen grid. This can be seen in the next diagram.

## FINAL STAGE PULSE SHAPING

The remainder of the control circuitry performs the pulse shaping for the screen voltage that feeds the output valve. The low-pass filter needs to be a linear-phase type to prevent the distortion of the pulse. Butterworth or Chebyshev filters do not have the correct response to a step impulse, and the pulse will over-

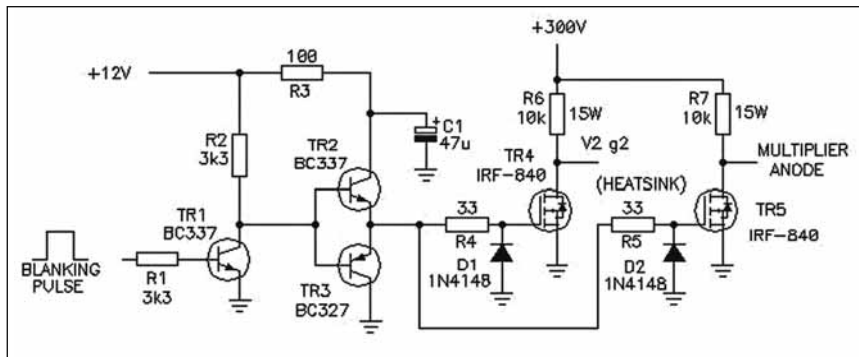

**Fig 7.6:** Circuit for the switching supply to the multiplier and driver stage screen grid

# Low Frequency Radio Astronomy

## *In this chapter:*

- Jupiter signals
- Directional beams
- The Io effect
- Receiving the noise storms
- Lower frequency experiments

**W**hereas many amateurs are under the belief that the frequencies used for radio astronomy are in the VHF, UHF and microwave spectrum, this is not so. There are several lower-frequency bands where radio noise from planets and other objects emit strong radio signals.

We have already mentioned one meteor radar system operated by the University of Adelaide, Australia on 2MHz and further details will be given later.

For the amateur with a limited station, a topic that is of much interest is HF radio astronomy. The following is based upon an article written by Jim Kennedy, K6MIO / WB4OUC of the University of Florida, USA. It was first published in the August 1971 edition of *73 Magazine*.

## JUPITER SIGNALS

The story of the puzzle begins in 1955 when two astronomers, K L Franklin and Bernard Burke, were testing a new 22MHz radio telescope. Quite unexpectedly, they discovered strong sporadic emissions from the vicinity of the planet Jupiter.

Jupiter is the largest of the planets in our solar system. This giant has a diameter that is more than 12 times that of Earth and it is so massive that it is believed it just missed becoming a star. Its surface is shrouded by layers of cloud beyond which lie 12 known moons. The four largest of these moons are bright enough to be seen with a pair of binoculars. In fact, Galileo discovered them the first time he turned his primitive telescope on this bright object.

In the years since the initial discovery of these radio signals, investigations have led to a number of interesting discoveries. Among these are that the emissions are essentially confined to a region below 30MHz, ie the region covered by normal communications receivers. The energy contained in these bursts of

Fig 11.1: Typical pen-recording of Jovian signals

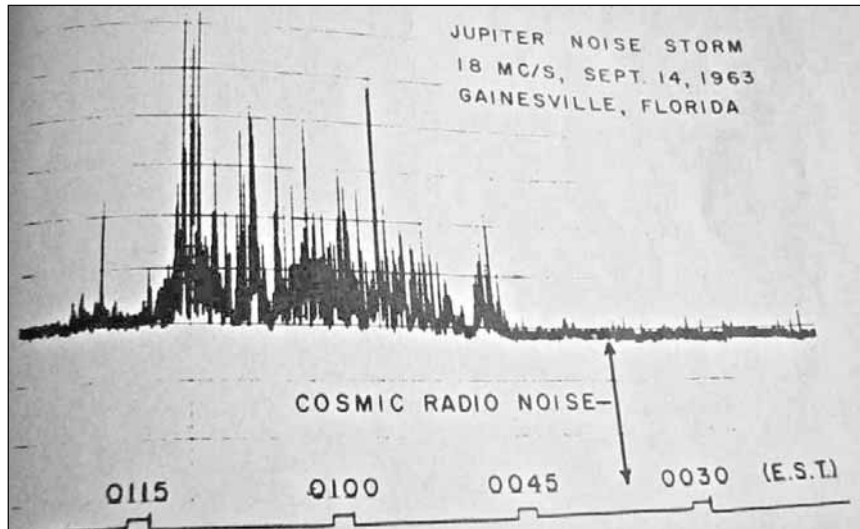

activity is so enormous that a simple three-element antenna and a communications receiver are all that is required to hear them.

The bandwidth of these signals is relatively narrow, sometimes no wider than 300kHz. Such an effect definitely points to a type of resonance effect taking place and being responsible for the generation of the signals. When observed, the signals may appear on one frequency and then gradually drift in frequency either up or down for several megahertz and then disappear.

It has been positively established that the lower the frequency, the greater the chance of occurrence. When heard with an AM receiver, the Jupiter (or Jovian) signals sound very similar to an unmodulated carrier being swished backwards and forwards across the frequency. Interspersed with the swishing are shorter pops.

The swishes, which last of the order of a second or two, are sometimes called L- (for long) bursts. The L-bursts are thought to be the result of scintillation (twinkling) of longer pulses of radio noise. The clouds of electrons that flow out from the Sun into the space between Earth and Jupiter cause this scintillation, through which the signal travels. The short pops are often called S- (for short) bursts. These appear to be caused by some mechanism at the source, and their explanation may well be an important clue to the cause of Jovian emissions.

## DIRECTIONAL BEAMS

Another curious effect is that the signals seem to be directional in nature. That is, it appears as if the radiation is confined to beams about  $70^\circ$  wide and originate from specific confined areas of the planet. Observations indicate that the emissions observed are originating from no more than three or four locations that rotate with the giant planet. Radiation is detected only when those regions of the planet face Earth. Measurements made by two different techniques suggest that the source size has an upper limit of 400km, and may be as small as 3km.

Narrow beamwidth, directional beams, and fixed localised and limited sources quite naturally lead to speculation that the signals might be the result of some 'intelligent' activity. However, partial explanations for these effects based

# A Hydrogen Line Receiving System

## *In this chapter:*

- The hydrogen line
- Equipment required
- Low-noise amplifier design
- Single stage design
- Additional receiver circuits
- 2nd IF & demodulator module
- First mixer module
- Local oscillator module
- Low noise oscillator supply
- Multiplier stages
- Choice of crystal type

**I**n Chapter 6, we considered some of the possibilities, when choosing a system to receive radio astronomy signals. In this chapter, we now consider the requirements for a particular application, the equipment necessary to receive signals at the Hydrogen Line at 1420MHz.

The Search for Extra-Terrestrial Intelligence programme (SETI) normally focuses on the Hydrogen Line as being the most likely frequency that a form of intelligence would use to try to convey information to some distant galaxy. Before we examine the equipment requirements in detail, it is perhaps useful to see why the Hydrogen Line is the most likely frequency and some of the practical limitations.

## THE HYDROGEN LINE

Hydrogen exists in copious quantities spread throughout space. Scientists today believe that 80% of all matter in space is comprised of hydrogen. The exact number of hydrogen atoms existing in deep space has been estimated as being one atom of hydrogen for each cubic centimetre of space. In other words, it is extremely thinly spread but, then again, there are an awful lot of cubic centimetres contained in space. The first clue that an emission may occur at 1420MHz was made by a Dutch astronomer H C van de Hulst in 1944, but it wasn't until 1951 that an emission was observed by Ewer and Purcell in the USA. The equipment the Americans used was quite crude, a 1m diameter parabolic antenna and a crystal detector; even so the signal was easily resolved.

In stars, hydrogen atoms are converted into helium, at the rate of four atoms of hydrogen to make one atom of helium. The word helium is derived from the Greek word Helios, meaning 'from the Sun'. The evolution of a star occurs when

sufficient hydrogen has been attracted into a small volume by gravity from a massive body, where the density and pressure are very high and the reaction can start. As the hydrogen is converted an enormous amount of energy in the form of heat and light is generated, our Sun is currently burning hydrogen at the rate of about 4 million tons per second.

A component of the radio emission from the Milky Way comes from the spin flip transition of the hydrogen atoms in the interstellar medium. This spectral line arises from the fact that the electron and the proton in the hydrogen atom have a particular direction of spin. The energy of the configuration where the spins are aligned is different from that when the spins are in opposite directions. This difference in energy is emitted when the atom goes from one state to the other and has a wavelength of 21cm, a frequency of 1420MHz. Since the emission comes from the hydrogen atoms in the plane of the galaxy, the velocity of the line with respect to the solar neighborhood (or the local standard of rest) can be used to study the structure of the galaxy and its rotation.

The fact that we can receive signals from the hydrogen atoms present 'chirping' at 1420MHz allows us to search the sky for changes in the level received. Where the mass of hydrogen is greater, we expect to receive a stronger signal. This will occur in some parts of space where no known star or other object exists, but large hydrogen gas clouds are known to exist. In some areas of space, the hydrogen atoms are excited by the intense radiation from a nearby star.

Of interest, stars as well as emitting signals across a broad band of spectrum, as our Sun does, also emit signals at the hydrogen line frequency of 1420MHz. In optical astronomy, many hydrogen-line-emitting stars in the optical spectrum are not visible because of the dense clouds of dust between them and the observer on the Earth. Because radio waves have a much longer wavelength than light, they are able to penetrate the dust clouds and so signals can be received on Earth from these distant objects.

### **Doppler Shift**

If we listen on the hydrogen line frequency of approximately 1420.4MHz and the signal is being radiated by a receding star, the frequency will be shifted in frequency due to the Doppler Effect. If the star is moving away from us at a great velocity, the signal is shifted lower in frequency. The average velocity of a star moving away from us is about 50kms<sup>-1</sup>. By knowing the exact signal centre frequency, we can calculate the effective velocity of recession. The exact centre frequency of the main hydrogen line is 1420.40575MHz without Doppler. With an object receding at 50kms<sup>-1</sup>, the signal will be shifted 237kHz lower in frequency. Hence, the local oscillator in the down-converter will need to be made adjustable to get the signal within the centre of the IF pass-band.

## **EQUIPMENT REQUIRED**

If you follow the list of equipment shown in Chapter 6, the minimum equipment consists of an antenna, an LNA and a down-converter with a tunable IF. At the hydrogen line, we have a choice of antenna types to use. The best approach would be a parabolic antenna (dish), as it then could work on several bands by changing the feed mechanism. Another choice could be long Yagis or a large corner reflector. Making a dish for 1420MHz of about 3m to 5m is

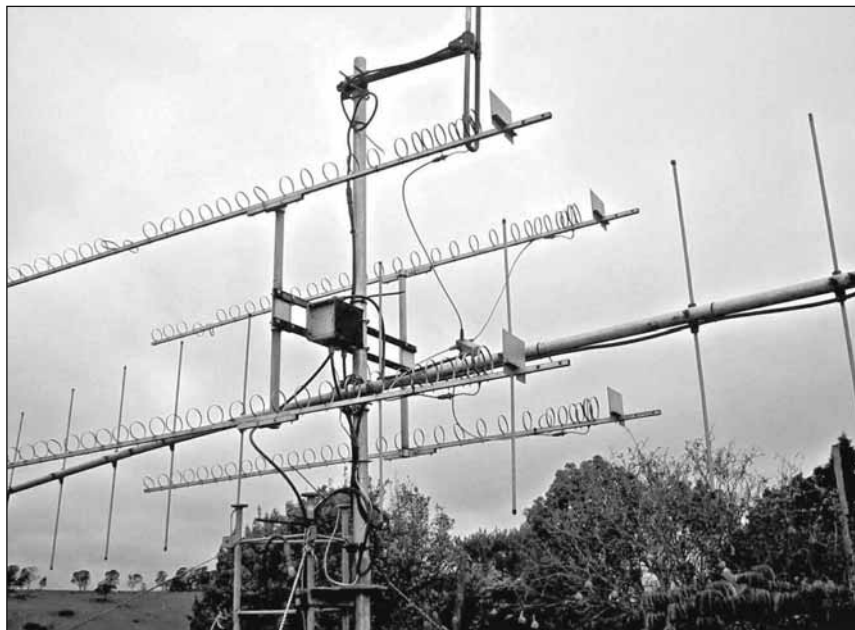

**Fig 13.1: G3JVL loop-quad antenna x 4, for 23cm. (Note the damage to the loops due to large perching birds!)**

not that difficult, Although time-consuming, it would repay the effort spent as it could also be used for EME on 23 or 13cm. The long Yagi design offering the best gain would be an array of loop quads following the G3JVL design. These are easier to make and offer a far lower wind resistance than even a small dish. Four G3JVL loop quads will achieve about 26dBd of gain, which is equivalent to a 4m diameter dish. A single large corner reflector can achieve about 18 to 22dBd of gain.

The LNA needs to be carefully considered. For the ultimate sensitivity, we need a very low noise figure. At this portion of the spectrum, the sky noise temperature will be below 15K for an antenna pointed at the zenith, so a noise figure of 0.2dB or lower is practical. With the advent of very low-noise PHEMT devices, this becomes possible at a modest cost. The author is currently designing a SETI system with a 0.2dB noise figure using two inexpensive Agilent PHEMTs. Using the analysis software SysCalc, the sensitivity of the receiving system was determined when an LNA of 0.2dB noise figure was used with a receiver bandwidth of 2.5kHz (SSB filter). This receiver is designed as a Dicke receiver, with a changeover relay between the antenna and the LNA with an insertion loss of 0.1dB (see Chapter 3 for details). The system noise figure to a first order is therefore approximately 0.3dB and the MDS is -139.7dBm. This, with a modest antenna, will give reasonable results.

The down-converter can be a type as used on 23cm with retuning and a change of crystal frequency for the local oscillator. At 23cm, the image rejection requirement normally dictates the use of an IF at 50MHz or 144MHz, although there is an advantage in using a lower IF. Generally, it is a mistake to make the IF less than 10% of the signal frequency, because of the image filtering problems.

The choice of IF is determined by the potential interfering signals that may be present at the image frequency. In the author's design, the first IF was chosen to



be 140.4MHz and a first LO of 1280.000MHz was used. This placed the image at 280.8MHz below the signal frequency, ie at about 1140MHz. A two-pole filter was made to eliminate the image response; this has an insertion loss of approximately 1dB. (The same filter was duplicated and tuned to serve as the band-pass filter following the final LO multiplier). Provided the gain of the LNA is much greater than the insertion loss of the filter and the coaxial cable between the antenna and the main receiver, the system noise figure will only be degraded by a fraction of a decibel.

If a second down-converter follows the first, and the second IF arranged to be somewhere in the HF spectrum, we could then use an HF receiver (with its wider tuning range) to search for signals several megahertz from the centre frequency. Depending on what receiving equipment you have will determine the best approach. Many modern HF transceivers offer general-coverage receivers with a wide choice of IF bandwidths. It would be advantageous to utilise a logarithmic amplifier to drive a meter or chart recorder to allow better detection. The AGC needs to be disabled and the gain adjusted manually for optimum results.

For best results, the final IF bandwidth needs to be narrow. Even 500Hz is not too narrow and the use of such a very narrow IF bandwidth will improve the system sensitivity considerably. The hydrogen line is more like a coherent signal than the normal broadband noise case, because the bandwidth is only a few hertz. However, this places an extra strain on the local oscillator stability and frequency-setting accuracy required to hold such a narrow-band signal within the IF pass-band. Also, the Doppler shift needs to be taken into account.

## LOW-NOISE AMPLIFIER DESIGN

The basis of a low-noise amplifier design using Agilent PHEMTs is now described. The device chosen is the ATF-34143, which is an SMD device in the SOT-343 package. This device is readily available and offers a noise figure of approximately 0.14dB at 1.5GHz when correctly noise-matched to the antenna. The ATF-34143 is a depletion-mode PHEMT and hence requires a negative gate voltage with respect to the source to bias it correctly. Although a negative bias generator could be used, a simpler method is to use active source-biasing with a resistor to set the required gate voltage. (Using a switching converter to generate the gate voltage is often not the best option, as even a very small amount of ripple voltage at the switching frequency will amplitude-modulate the gate signal and cause noise sidebands to occur. If the switching ripple is as low as 0.01 of 1 $\mu$ V, this will still be detectable as noise sidebands.)

The biggest problem designing with PHEMTs and GaAsFETs at low frequencies is obtaining sufficient device stability. If the device is not stabilised across a wide range of frequency, the device can oscillate and will give a very poor noise figure. The second problem is attaining the required noise match to the 50 $\Omega$  antenna. In normal low-noise amplifiers, the choice is often to resonate the gate capacity with a high-Q inductor or section of transmission line to achieve the mismatch required. For the traditional GaAsFETs used up until now, this is often the best option, PHEMTs are slightly different and require a different technique. The portion of spectrum from 70cm to 13cm is a transitional area between traditional inductors and strip-line designs.



# Index

- American National Radio Astronomy Observatory . . .13
- Amplifier
- handling strong signals . . . . .183-184
  - input network . . . . .244-245
  - intermodulation performance . . . . .184
  - logarithmic . . . . .106-107, 223, 265
  - low-noise (LNA) . . . . .78, 81, 82, 87, 102-103  
. . . . .179-185, 189, 228-229  
. . . . .235-256, 258, 262-263, 301-302, 306-316
  - low noise GaAsFET, 432/1296MHz . .247-250
  - parametric . . . . .182-183
  - shielding, filtering and switching . . . . .254
  - tunnel diode . . . . .181
- Antenna
- bandwidth . . . . .126-130
  - Bruce array . . . . .9
  - combiner . . . . .227
  - corner reflector . . . . .297-299, 304
  - dipoles . . . . .34, 35, 64, 75, 120, 127, 171-176  
. . . . .277, 295
  - end-effect . . . . .140-141
  - feed impedance . . . . .132-134
  - for meteor scatter . . . . .296-301
  - front-to-back ratio . . . . .120, 130, 300
  - gain and directivity . . . . .44, 47, 81, 64  
. . . . .117-121, 130, 139, 166, 170  
. . . . .171-173, 291, 295, 296, 298
  - loop-quad . . . . .305
  - measurement . . . . .139-140
  - multi-band . . . . .300
  - parabolic dish 10, 12, 19, 24, 28-33, 35-38, 60  
. . . . .62, 120, 148-166, 304, 329-331  
. . . . .334, 335
  - parameters . . . . .117-178
  - polarisation . . . . .145-147
  - special configurations . . . . .166
  - stacking distance . . . . .123-125, 297
  - systems, special . . . . .295-301
  - trough reflector . . . . .299
  - vertical radiation angle .134-135, 289, 291, 295
- Yagi . . . . .22, 23, 24, 27, 40, 74, 112-133  
. . . . .175, 176-177, 189, 280  
. . . . .289, 291, 295, 296-297, 332
- Antenna mount
- az-el mount . . . . .12, 13, 19, 189
  - meridian mount . . . . .19
- Arecibo Observatory . . . . .60, 62, 150, 293, 294
- Army Operational Radar Group (AORG)  
. . . . .14, 22, 26, 40, 280
- Astronomical Unit . . . . .52
- Audio filter, narrow-band . . . . .267-268
- Australian Antarctic Research base, Davis . . . .72
- Australian Council for Scientific and Industrial  
Research Organisation . . . . .13
- Automatic gain control (AGC) . . . . .43, 189, 306
- Baluns . . . . .141-143
- Bay, Zoltán* . . . . .34, 48
- Bayer, Johann* . . . . .206, 207
- Bell Telephone Laboratory . . . . .9, 10, 14
- Blackett, Dr P M S* . . . . .21, 22, 23, 26, 28
- Bowen, Edward George (Taffy)* . . . . .37
- Briggs, Dr B H* . . . . .277
- Buckland Park, Adelaide . . . . .72, 73, 74, 277, 284  
. . . . .286, 289, 290, 294
- Burke, Bernard* . . . . .273
- C-band radio telescope, simple . . . . .198-201
- Cable loss . . . . .125
- Cassiopeia-A . . . . .86, 147, 201, 204
- Catalogues, radio object . . . . .202
- Centaurus-A . . . . .204
- Chaff (or Window) . . . . .61
- Clegg, J A* . . . . .23, 55
- Coaxial cable lengths, myths about . . . . .140
- Coaxial stubs . . . . .137, 143
- Comets . . . . .281-283, 287
- Conductivity, electrical . . . . .154-158

Connectors,	
losses in	.246
mounting	.312
Cooling, liquid helium	.82, 100-102, 185
Cosmic particles, echo from	.22-23
Crab Nebula (Taurus-A)	.30, 204, 205
Crystal	
choice of type	.325-328
ovens	.326-328
Cygnus-A	.27, 79, 86, 95, 147, 148, 201, 204
Decibel	.45
Declination	.194
Dicke switching	.85, 91-94
Digital signal processing (DSP)	.90, 92, 104
Display	
A-scope	.42
CRT	.41, 43
pen (chart)	.77, 86, 190
Plan Position Indicator	.42
Doppler shift	.33, 35, 36, 50, 64-65
	.86, 285, 286, 304
Durban University of Technology	.329, 332, 342
Effective radiated power (ERP)	.44, 45
EISCAT	.292-293
<i>Elford, Dr Graham</i>	.55, 56-58, 277, 284, 286
Faraday rotation	.35, 145-146, 194
Feed horn supporting struts	.352-355
Feed line considerations	.191
<i>Franklin, K L</i>	.273
Frequencies for radio astronomy	.98
Frequency multiplier stages	.322
Fresnel Zone effects	.75, 285
GaAsFET (see Semiconductors)	
<i>Galileo</i>	.273, 275
Hartebeesthoek RAO demonstrator antenna	.367-372
Head-echo effect	.59-60, 292-294
<i>Heightman, J W</i>	.14
<i>Herlofson, Nicolai</i>	.23, 59
<i>Hey, J S</i>	.14, 21, 22, 26, 40, 46, 54
	.55, 66, 94, 280, 283
<i>Hoch, Gunther, DL6WU</i>	.44, 120
Horsehead Nebula	.205-206
Hubble space telescope	.30, 31
<i>Hulsmeyer, Christian</i>	.8
<i>Husband, Charles</i>	.28, 30, 154, 155
Hydrogen Line	.20, 36, 78, 87, 88, 90, 154, 155
receiving system	.303-328
Interference (see also Noise)	.96
Interferometer network	.31-33, 167-170, 171
MERLIN	.31, 170
Ionosphere	.8, 9, 54, 276, 277, 280, 287
Isotropic source	.148
<i>Jansky, Karl G</i>	.9, 27, 94
Jodrell Bank Observatory	.21-33, 35-36, 39, 52
	.53, 59, 62, 81, 82, 87-90, 91
	.96, 120, 149, 152, 153, 154, 155-157, 177
	.280, 283
Jupiter signals	.273-277
Io effect	.275
<i>Kraus, Dr John D, W8JK</i>	.86, 120, 147
Legal requirements	.331
Libration fading	.34, 51
Light year	.207
Lodge, Sir Oliver	.5-7
Loss, free space	.45
<i>Lovell, Sir Bernard</i>	.20-26, 28, 30, 32, 35
	.39-41, 46, 53, 54, 66, 154, 155, 280, 283
Low frequency radio astronomy	.273-278
<i>Marconi, Guglielmo</i>	.7
Matched filter	.48
Max Planck Observatory	.62, 11
Mechanical system considerations	.329
Mesh aperture considerations	.330
Meteor	.56, 280
daily counts	.294
daytime showers	.283
echoes	.14, 22, 23, 24, 27, 40, 55, 60, 72-75
ping detector circuit	.269-270
radar system, 50MHz	.209-234
range to	.290
reflection equation	.56
scatter communication	.188, 189, 190, 279-302
trail	.56, 57-58, 72, 74, 279-302
types	.285-286
velocity	.24
Meteorite	.56, 280
Meteoroid	.56, 72, 280
Milky Way	.9, 97, 304
<i>Mills, Dr B Y</i>	.172
Minimum detectable signal (MDS)	.48, 49, 54, 78
Missiles, V-1 and V-2	.16, 17, 19, 22, 27, 42
Molonglo, Australia	.173

Modulation	70-71
Moonbounce (EME)	33-36, 78, 145, 146, 187 190, 193
Moon, the	13, 33-36, 51, 52, 61, 62, 94, 207
Lunar probes	35
Mount Wilson optical telescope	30
Mullard Observatory, Cambridge, UK	20
Naval Research Laboratory	9
Noise	
background microwave radiation	83
electrical storms	9, 276
equivalent resistance (ENR)	181
factor	181
image	79-81, 263
man-made	11, 48, 188
measurement systems, professional	261-262 264
power	82-85
random ('grass')	41
receiver (see Receiver, noise)	
solar	14, 15, 49
source, hot-cold	257-258
source, broad-band	258-261
sky	12, 13, 74, 83-85, 103, 147
temperature	102, 104, 302, 305
test method for noise figure	264-266
North and South Pole correction	195
<i>Nuffield, Lord (William Morris)</i>	28, 31
Object naming system	204-207
Parkes Observatory, Sydney	37-38, 151, 152
<i>Pawsey, Dr John</i>	37
Planets	36, 52, 62, 205, 273, 262
Positioning systems	335-349
power supplies for	349-351
Post-detection signal enhancement	50
<i>Prentice, J P M (Manning)</i>	23, 53
Product detector	270
Project Diana	33, 48
Pulsars	33
Pulse modulator	69
Pulse Repetition Frequency (PRF)	52, 53, 65, 66 73, 75, 295
Pulse shaping methods	69-71, 314-217
Pulse width	48
Quasars	33

Radar	
acronym for	39
astronomy	39-75
Chain Home	16, 17, 18, 24, 42, 66
experiments by Marconi	8-9
German wartime	13, 17, 40
GL2	40, 42, 48, 54, 63, 64, 65, 66 167, 280
H2S	21, 39, 41
in Marshall Islands	59, 293
J-watch	14
meteor, 50MHz	201-234
range	44-47, 50-59
scattering equation	288-289
Standard Equation	46
Radio Australia	34
Radio-Eyes software	195-198
Radio flux unit (the Jansky)	94, 147
Radio horizon	95-96
<i>Reber, Grote (W9GFZ)</i>	10-13, 27
Receiver	12, 41, 77-116
50MHz	220-225, 231-232
bandwidth	49, 50, 84, 85-86 94, 190
basic components	187
basic requirements	189-190
filtering, special techniques	111-114
IF	61, 79, 92, 222-223, 270-271 305, 317-318
local oscillator module	319-321
mixer module	318-319
modern approach	87
noise	46, 49, 78, 79-82, 99, 113 257-266
parameters for meteor scatter	302
post-detection processing	225
sensitivity	46, 47, 78
special techniques	104
system calculations	114-116
simple, radar	42-44
Recording techniques	190
Reflectivity of target	46, 61
Right ascension	194
Rollet stability factor	308
RSSI	109-110
<i>Ryle, Dr Martin</i>	31, 168
Sagittarius	9, 97, 189, 207
SCR-270	33

Semiconductors	
bipolar junction transistor	.236-238, 322-325
GaAsFET	.184, 242-242, 247-249, 306
HEMT and PHEMT	.184, 185, 236 .247-249, 306
integrated circuits	.108-110
JFET	.238-239
MOSFET	.228, 240-242
package types, typical	.253
transistors	.71
tunnel diode	.181
Sensitivity time control (STC)	.43
Sidereal day	.9, 25, 283
Signal source, low power	.268-269
Skin depth and ohmic loss	.131-132
Spectral spreading	.67
Sputnik	.29, 35
Station,	
accessories	.267-271
assembling a	.187-208
Sun	.36, 207
radiation from	.5, 79
Support structure, rigidity of	.332
System budget calculations	.191-194
Taurus-A (see Crab Nebula)	
Transmitter	.41
50MHz	.210-218, 232-234
low-pass filter for 50MHz	.229-230
power	.47, 66
requirements for	.65-67
TRE Malvern	.20, 23, 28, 32
TVRO dishes	.198, 201
US Army Signal Corps	.33
Valves	.66-67, 70-71, 209, 210-213, 217-218
klystron	.182
noise performance of	.179-181
nuvistor	.181
<i>van de Hulst, H C</i>	.36, 155, 207
VSWR	.126-129, 135-137, 139, 140, 142, 144
<i>Wallace, Sir Barnes</i>	.37
Wind loading	.154
<i>Whipple, Fred</i>	.282
Year	
Besselian	.203
Gregorian	.203
Julian	.203, 204
Zeppelin	.16, 17